

LAGRANGE COUNTY HEALTH DEPARTMENT

304 N. Townline Rd., Suite 1, LaGrange IN 46761-1319 ♦ Phone (260) 499-4182 Ext. 222 Fax 499-4189 agarcia@lagrangecounty.org



STEP Systems Pumps (Effluent)

P-SE-13T

Features

- Carbon/Ceramic mechanical seal
- Piggy-back style float for automatic or manual operation
- Oil-filled motor with automatic reset overload provides safe c
- Ball bearing construction for long life

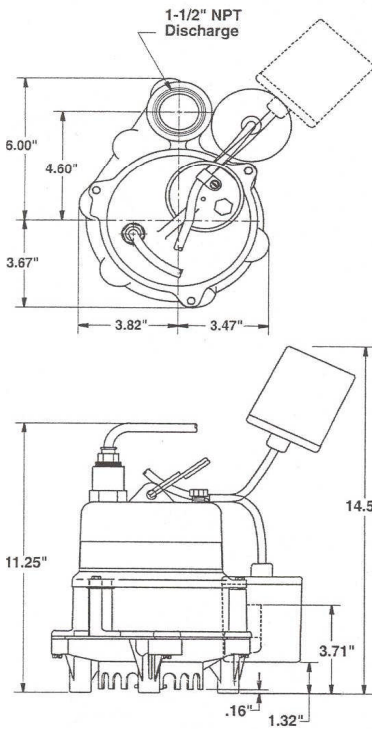

Specifications

Capacities: to 55 GPM

Heads: To 21 FT

Motor: 1/3 HP (1550 RPM)

Electrical: 115 V, 12.0FLA, 1Ph, 60Hz

Operation: Tethered float

Impeller: Thermoplastic, non-clog, vortex type

Solids Handling: 3/4" (19mm)

Power Cord: 20' (6M) 16-3, SJTW-A/SJTW

Discharge: 1-1/2"

Warranty for Defects in Material and Workmanship

- All components - 3 Years

AutoCad R-14 dwg files at www.zabelzone.com/autocad.htm

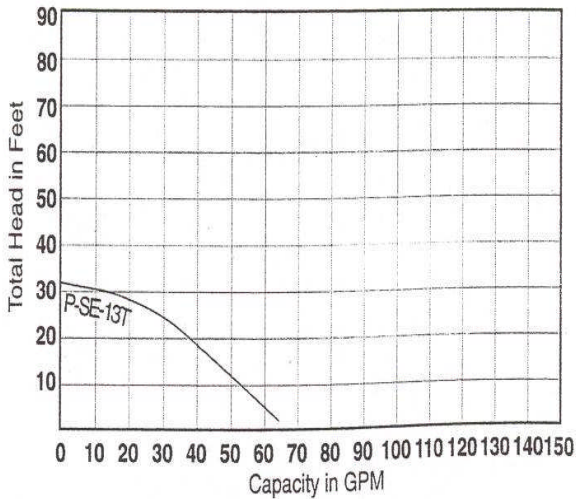

Pumps

Submersible Sump



P-SU-13T